

Item	Quantity	Description
1	4	2x4x10 Pressure Treated Wood
2	4	1x4x10 Roll-up Board
3	14	1.625"x4' Post
4	2	2x4x12 Pressure Treated Wood
5	10	1.375" x 10.5' Rib
6	2	2x4 End Wall Framing
7	1	1.375" OD Purlin
8	2	36"x80" Door

WIND LOAD - 65 MPH  
 SNOW LOAD - 30 PSF

UNLESS OTHERWISE SPECIFIED, DIMENSIONS ARE IN INCHES .XX = ±.0- .XXX = ±.00- .XXXX = ±.000- SURFACE FINISH <input checked="" type="checkbox"/>		NAME	DATE	Roberts Ranch Hoophouses	
DO NOT SCALE DRAWING	DRAWN	KEVIN ROBERTS	04/25/2021	TITLE 12' Wide Hoophouse End View & BOM	
BREAK ALL SHARP EDGES AND REMOVE BURRS	CHECKED				
THIRD ANGLE PROJECTION	APPROVED	E. Roberts			
	MATERIAL	FINISH		SIZE	DWG NO.
	Galvanized Steel			A	H20-1
				SCALE	WEIGHT
				1:32	
				SHEET	1 of 5
				REV.	A

2

1

B

B

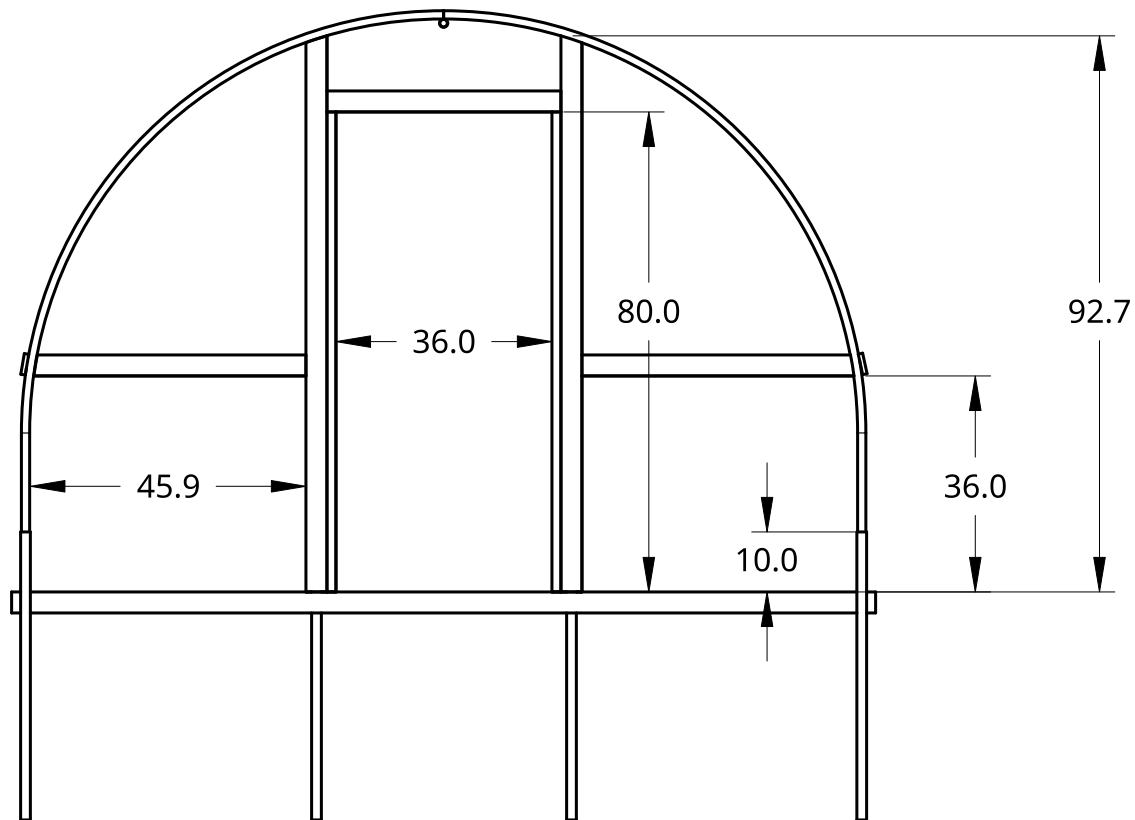



A

A

WIND LOAD - 65 MPH  
 SNOW LOAD - 30 PSF

2

1

UNLESS OTHERWISE SPECIFIED, DIMENSIONS ARE IN INCHES .XX = ±.0- .XXX = ±.00- .XXXX = ±.000- SURFACE FINISH 		NAME	DATE	Roberts Ranch Hoophouses	
DO NOT SCALE DRAWING		DRAWN	KEVIN ROBERTS	04/09/2020	TITLE 12' Wide Hoophouse Example Plan
BREAK ALL SHARP EDGES AND REMOVE BURRS		CHECKED			
THIRD ANGLE PROJECTION 		APPROVED			
WIND LOAD - 65 MPH SNOW LOAD - 30 PSF		MATERIAL	FINISH	SIZE A	DWG NO. H12-2
				SCALE 1:40	WEIGHT
				SHEET 2 of 5	
				REV. A	

2

1

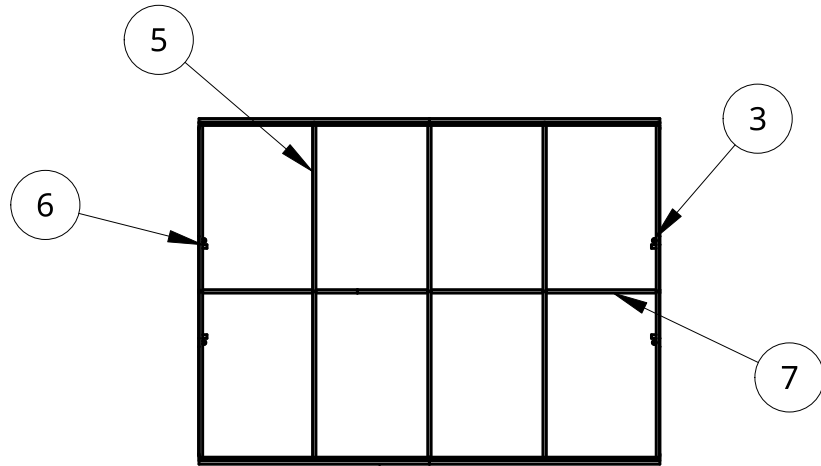

Item	Quantity	Description
1	4	2x4x10 Pressure Treated Wood
2	4	1x4x10 Roll-up Board
3	14	1.625"x4' Post
4	2	2x4x12 Pressure Treated Wood
5	10	1.375" x 10.5' Rib
6	2	2x4 End Wall Framing
7	1	1.375" OD Purlin
8	2	36"x80" Door

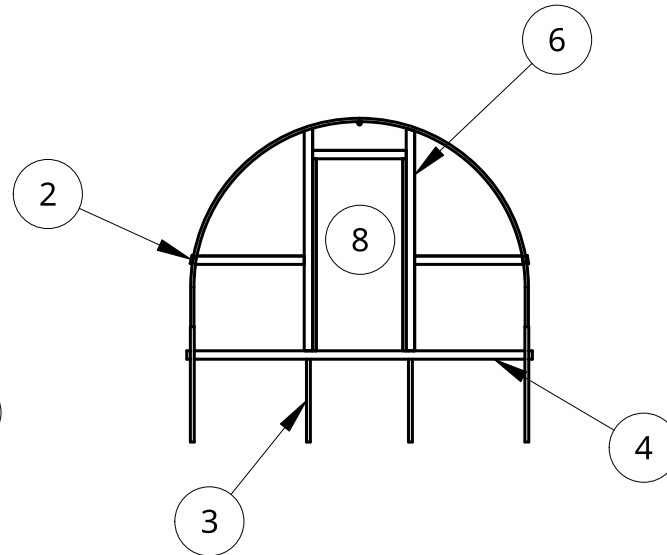
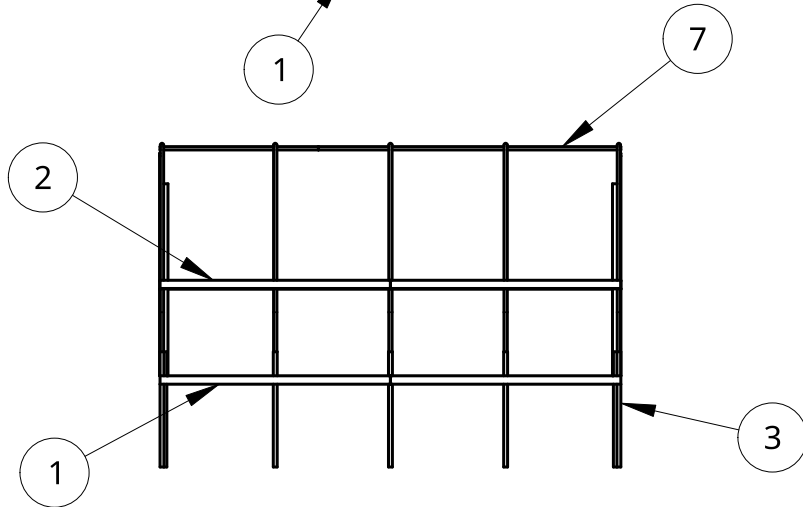

B

B

A

A

WIND LOAD - 65 MPH  
SNOW LOAD - 30 PSF

UNLESS OTHERWISE SPECIFIED,  
DIMENSIONS ARE IN INCHES  
.XX = ±.0-  
.XXX = ±.00-  
.XXXX = ±.000-  
ANGULAR = ± °  
FRACTIONAL = ±

SURFACE FINISH ✓

DO NOT SCALE DRAWING

BREAK ALL SHARP EDGES AND  
REMOVE BURRS

THIRD ANGLE PROJECTION

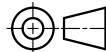

	NAME	DATE
DRAWN	KEVIN ROBERTS	04/25/2021
CHECKED		
APPROVED	E. Roberts	
MATERIAL	Galvanized Steel	FINISH

Roberts Ranch Hoophouses

TITLE  
12' Wide Hoophouse Project  
Views & BOM

SIZE	DWG. NO.	REV.
A	H12-3	A
SCALE 1:80	WEIGHT	SHEET 3 of 5

2

1

B

A

B

A

2

1

2

1

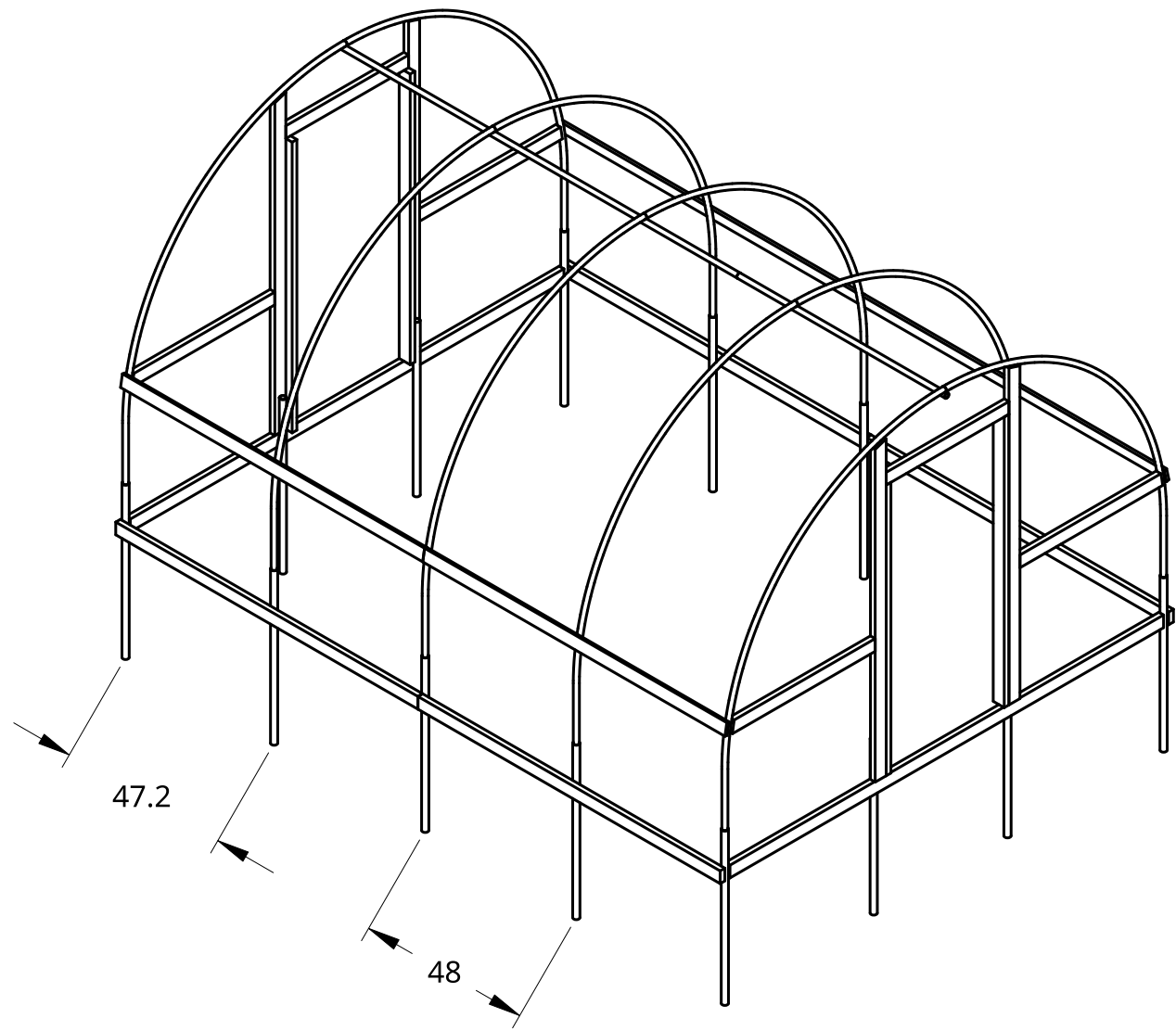

WIND LOAD - 65 MPH  
 SNOW LOAD - 30 PSF

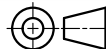
UNLESS OTHERWISE SPECIFIED, DIMENSIONS ARE IN INCHES .XX = ±.0- .XXX = ±.00- .XXXX = ±.000- SURFACE FINISH 		NAME	DATE	Roberts Ranch Hoophouses	
DO NOT SCALE DRAWING	DRAWN	KEVIN ROBERTS	04/25/2021	TITLE	
BREAK ALL SHARP EDGES AND REMOVE BURRS	CHECKED			12' Wide Isometric View	
THIRD ANGLE PROJECTION	APPROVED	E. Roberts		SIZE	REV. A
	MATERIAL	FINISH		DWG NO.	
	Galvanized Steel			H12-4	
		SCALE	WEIGHT	SHEET	
		1:40		4 of 5	

2

1

Item	Quantity	Description
1	2	1.375" x 10.5' Rib
2	2	1.625" x 4' Post

B

B

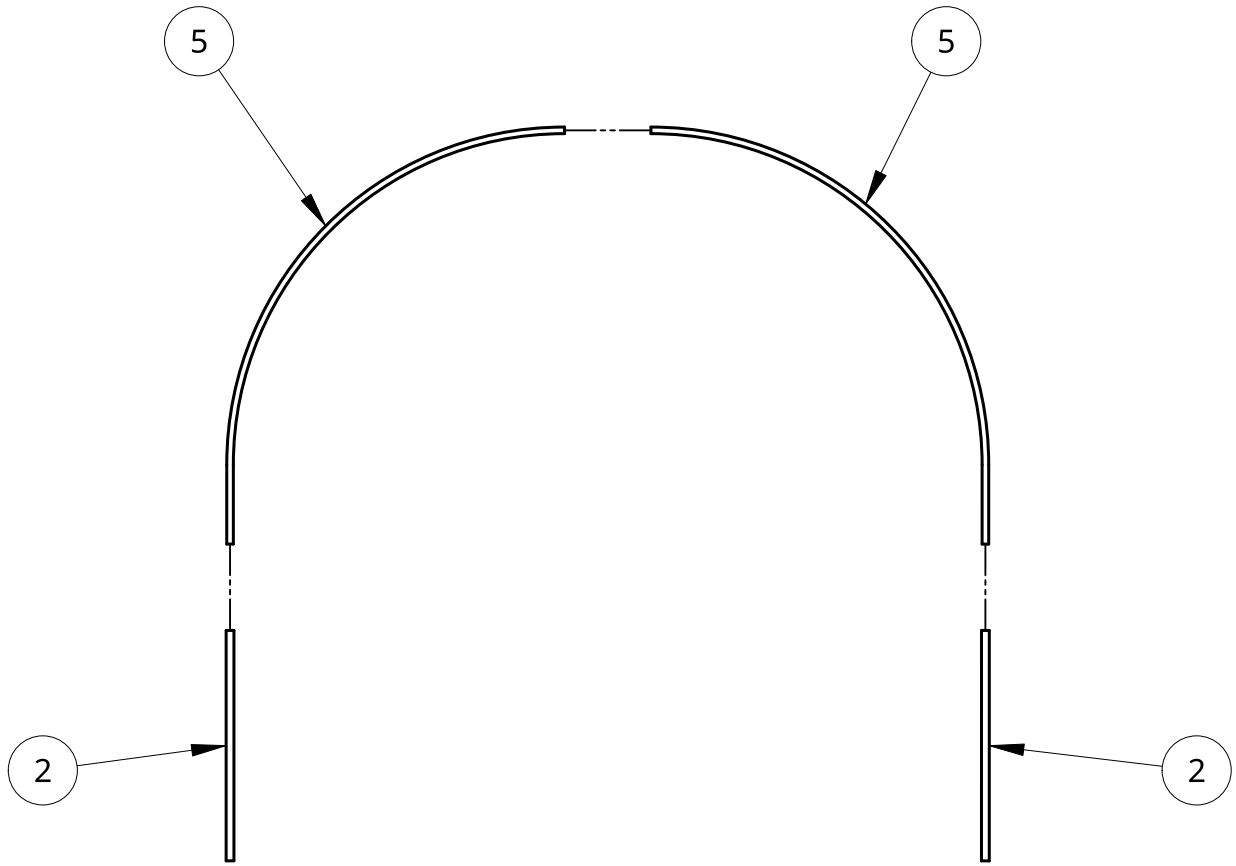

A

A

WIND LOAD - 65 MPH  
 SNOW LOAD - 30 PSF

2

1

UNLESS OTHERWISE SPECIFIED, DIMENSIONS ARE IN INCHES .XX = ±.0- .XXX = ±.00- .XXXX = ±.000-		NAME	DATE	Roberts Ranch Hoophouses	
SURFACE FINISH		DRAWN	KEVIN ROBERTS	04/25/2021	TITLE 12' Wide Hoophouse Arch Assembly
DO NOT SCALE DRAWING		CHECKED			
BREAK ALL SHARP EDGES AND REMOVE BURRS		APPROVED	E. Roberts		
THIRD ANGLE PROJECTION		MATERIAL	FINISH		SIZE A
		Galvanized Steel			DWG NO. H12-5
				SCALE 1:40	REV. A
				WEIGHT	SHEET 5 of 5